

Sewer Extension South LWMP Addendum

Public and Technical Advisory
Committee Meeting #4
November 22, 2023



The Comox Valley Regional District respectfully acknowledges the land on which we gather is on the unceded traditional territory of the K'ómoks First Nation, the traditional keepers of this land.

TACPAC Meeting #3.5, March 14, 2023

- Meeting Minutes
- Follow-up items
 - Revised Terms of Reference
 - TAC Roles and Responsibilities revised to include *“Where TACPAC meetings are held together, TAC members may abstain from voting on matters that are of specific interest to the community and/or where there is a perceived conflict with the TAC member’s role as a regulatory body.”*
 - PAC Roles and Responsibilities revised to include *“Where TACPAC meetings are held together, PAC members may abstain from voting on technical matters that do not impact the community.”*

Public Engagement Overview



Christianne Wile
Senior Manager Strategic Initiatives

Public Engagement Results 2021 - 2023



3 open houses
290 attendees



3 mail updates
4,500 letters sent



2 webinars
128 attendees



300 project
followers



2,500 page views
1,888 website visits
946 unique visitors



170 emails/calls
answered



- Websites: 505 - 49.70%
- Direct: 329 - 32.38%
- Search Engine: 97 - 9.55%
- Social Media: 63 - 6.20%
- Campaigns: 22 - 2.17%

June 2023 Community Engagement



SHARE YOUR FEEDBACK

Thank you for attending today. Your input is important to us and will be collected and reported out to the Province as part of the Liquid Waste Management Plan addendum process.

TWO WAYS TO SUBMIT YOUR FEEDBACK

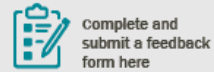

Complete and submit a feedback form here



Fill the feedback form out online

STAY UP TO DATE AT www.engagecomoxvalley.ca/sewerextension



Register to receive project updates



Get access to the latest news and events



Ask a question of our project team



Sewer Extension South Project Community Update Events

Royston and Union Bay Area Residents:
Join us to Learn More About Sewer Plans

Visit www.engagecomoxvalley.ca/sewerextension for event details.



Sewer Extension South Project: Community Events

We're taking next steps on the Sewer Extension South Project - and we want to update the community and impacted homeowners about progress to date, plus get feedback on critical project components.

JOIN US IN PERSON

 Tuesday, June 13
3:00 pm to 5:00 pm
Fallen Alders Hall
3595 Royston Rd, Royston

 Wednesday, June 14
5:00 pm to 7:00 pm
Union Bay Community Hall
5401 Island Hwy S, Union Bay

JOIN US IN ONLINE

 Wednesday, June 7
12:00 pm to 1:00 pm
To register visit:
www.engagecomoxvalley.ca/sewerextension

QUESTIONS?

Contact us at
E: communications@comoxvalleyrd.ca
P: 250-334-6000

The Sewer Extension South Project will bring community sewer service to Royston and Union Bay by connecting to the Comox Valley Sewer System that currently services Courtenay, Comox, Department of National Defense and K'ómoks First Nation. Come join us to find out more about how this impacts you.

What We Heard

Themes are listed in order of interest/popularity:



Costs/affordability



Timing/costs for future phases



Interest in connecting to the system now



No option for a referendum/AAP



Project being prioritized to benefit private property development



“Get the job done” as quickly as possible

By the Numbers

	902	Postcards direct-mailed to Royston/Union Bay residents		13	Questions asked and answered on project webpage
	215	People attended in-person open houses		34	Feedback forms submitted at in-person events
	43	Residents attended online webinar		12	Feedback forms completed online
	1,514	Engagement page views		36	Staff follow-ups by email and phone post-events
	29	Questions asked and answered during the webinar		201	Webinar views on YouTube

Public Engagement: Next Steps



**November 2023:
Community Update**



**January 2024:
Community Events**



March 2024: Report Back



First Nations Consultation Update



K'ómoks First Nation

Responses

- Cowichan Tribes
- Halat First Nation
- Homalco First Nation
- Qualicum First Nation

No Comment

- Hupačasath First Nation
- Lyackson First Nation
- Penlakut Tribe
- Snaw-naw-as First Nation
- Snuneymuxw First Nation
- Stz'uminus First Nation
- Tla'amin
- Ts'uubaa'asatx Nation
- Wei Wai Kum First Nation
- We Wai Kai first Nation

Draft LWMP Addendum Report



LWMP 3-Stage Process

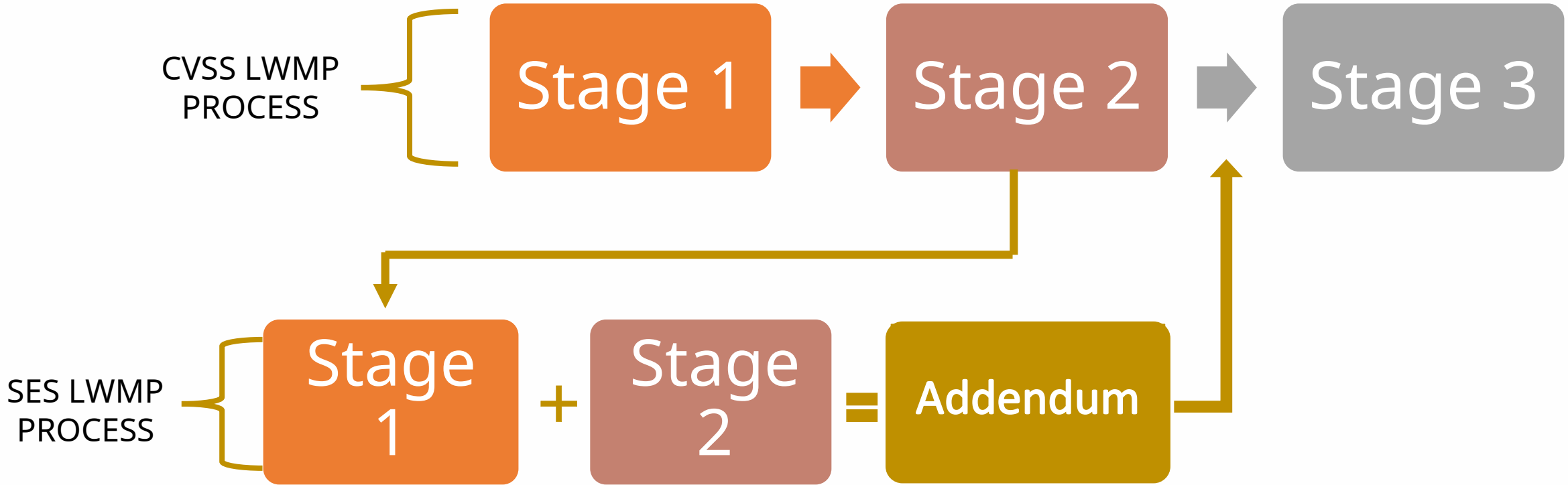

LWMP Addendum purpose

- Long-term plan for community liquid waste infrastructure
- Consider community growth and development
 - Regional Growth Strategy / Official Community Plan
 - Population projections
- Comprehensive consultation

Section 2 - Consultation

- Advisory Committee Meetings
- K'ómoks First Nation
- Public Consultation
 - Phase 1 – Project initiation
 - Phase 2 – Project details and costs
 - Phase 3 – Sharing draft Addendum report
- Other First Nations



Section 3 - Service Area, Land Use, Development, Population

- Existing and new development areas
- Land use policy context
- Population projections to 2070

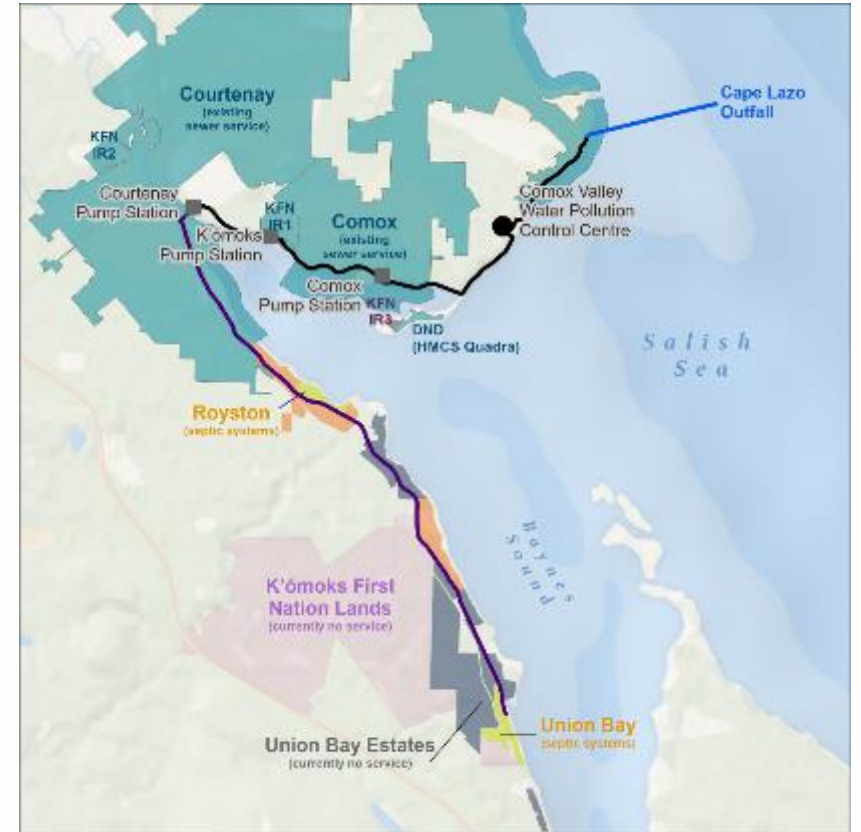

Section 4 - Regulations & Guidelines

- Inflow & Infiltration
- Volume Reduction
- Source Control
- Septic Systems

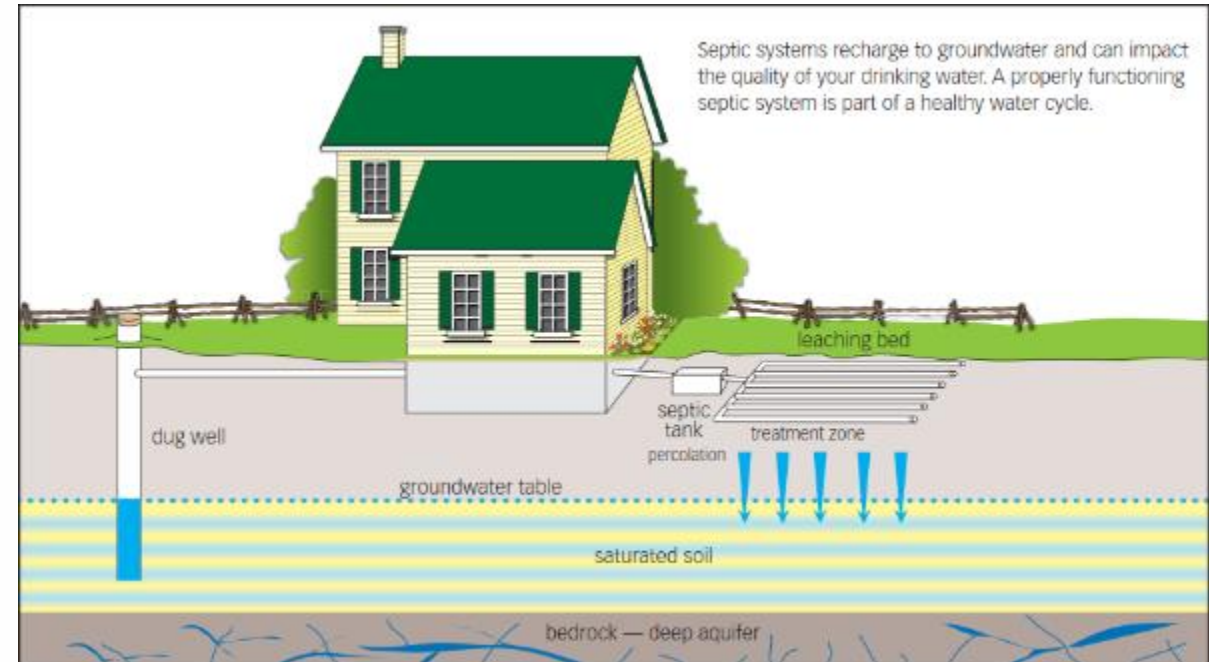

Section 5 - Project Design

- Flows & loads
- Design Constraints
- Phasing
- Project components
 - Collection systems
 - Pump stations
 - Forcemain

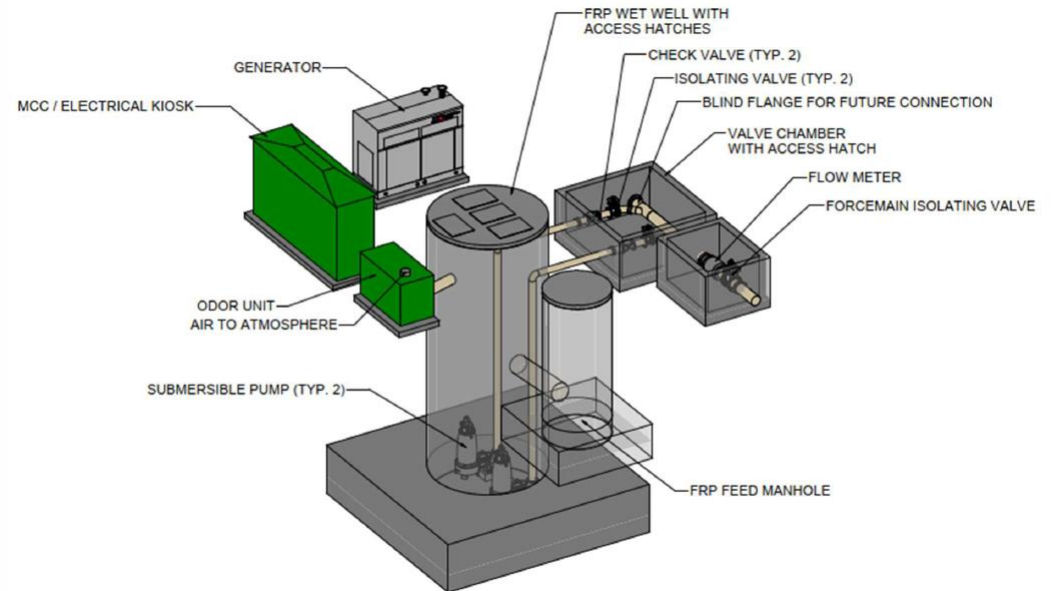

Section 6 - Environmental Impact Study

- Archaeology
- Environmentally Sensitive Areas
- Contaminated Sites

Section 7 - Project Cost Impacts

- Class 'C' cost estimates
 - Phase 1A
 - Phase 1B
- Cost escalation & internal costs
- Phase 1A property owner costs

Collection System design update



November 22, 2023

Engineering Design Process

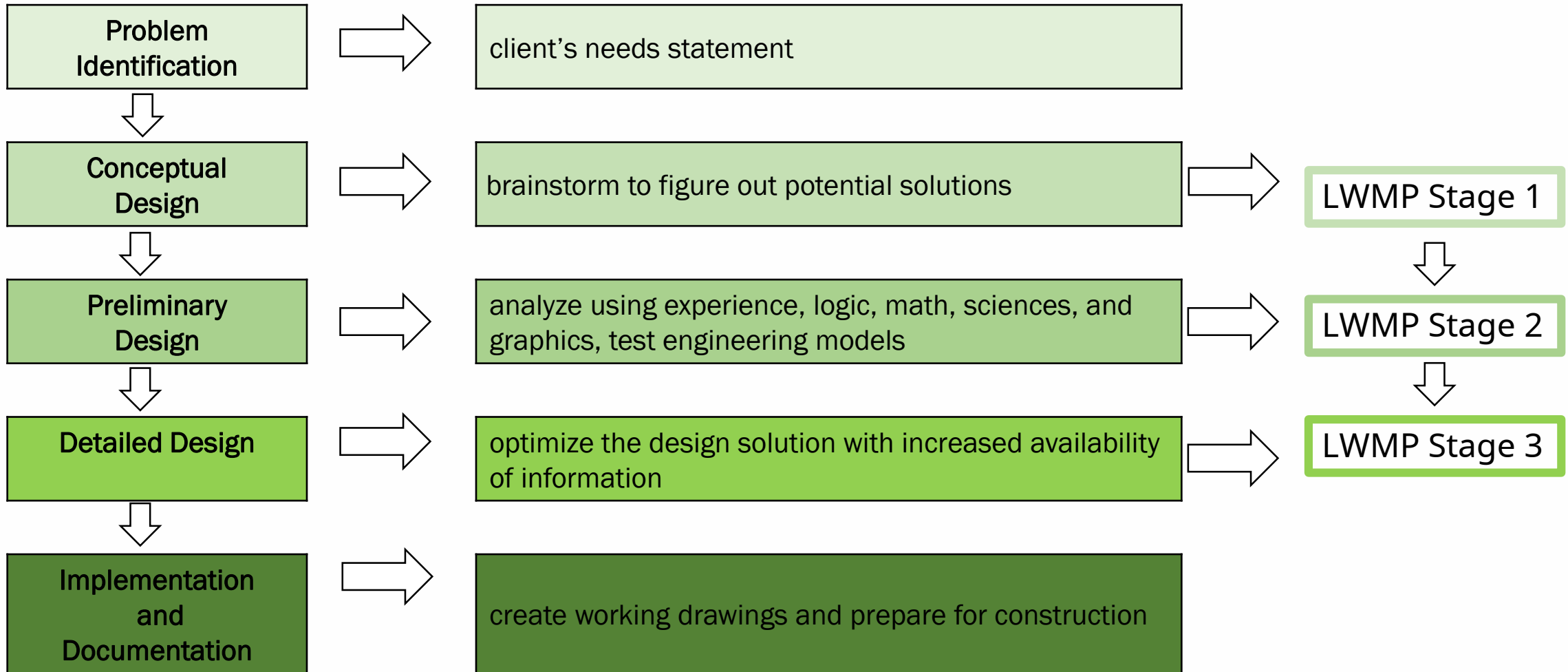

Updating the design

- Conceptual Design high-level information
 - High-level information
 - Various assumptions made
 - Statutory Right of Way (SRW)
- Preliminary Design
 - Additional information such as LIDAR and base mapping
 - Environmental assessment
 - Hydraulic modeling, pipe depth, velocities, and diameter
 - Value Engineering process
 - Public input

Planview: Royston

Conceptual Design

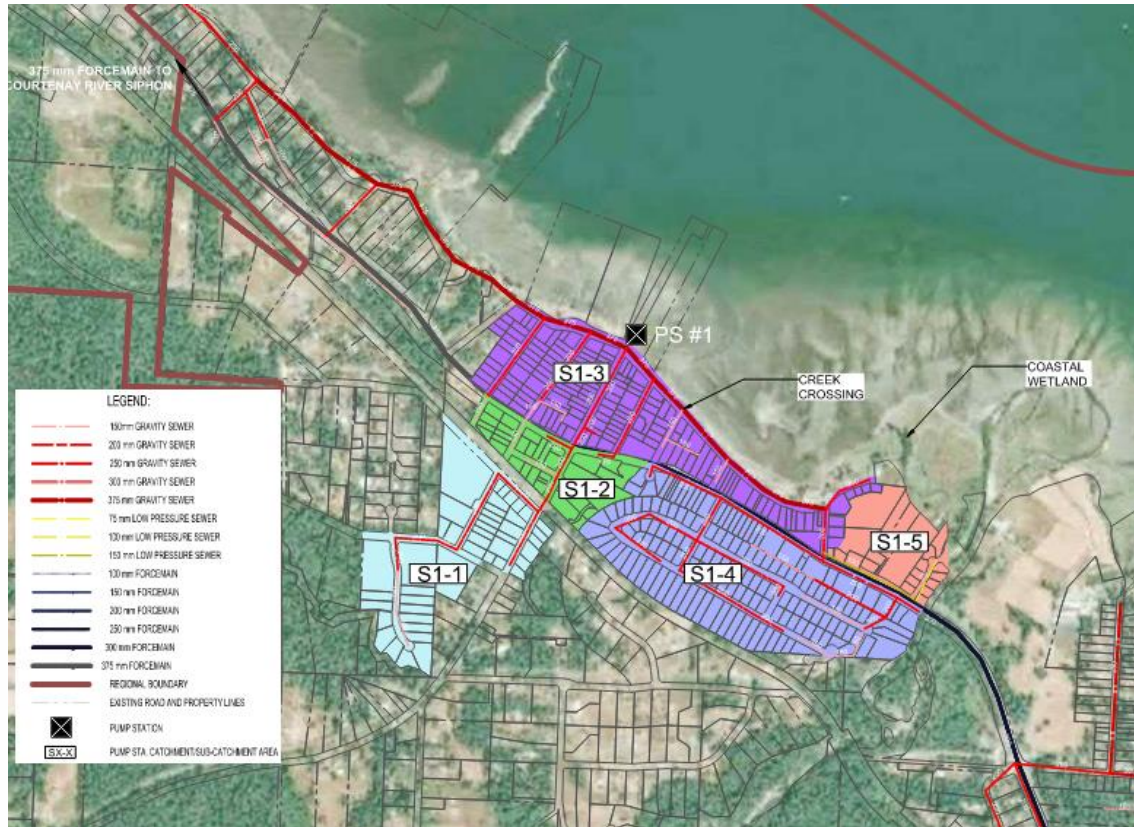

Preliminary Design

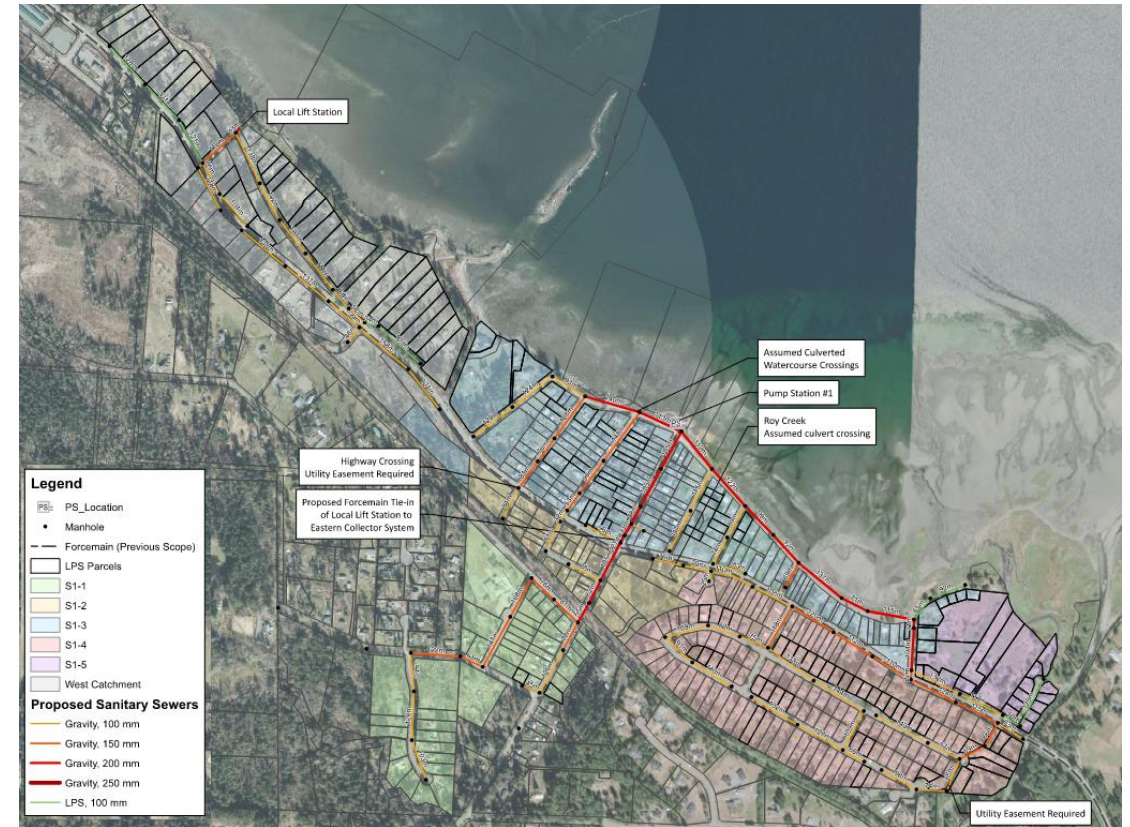

Planview: Union Bay

Preliminary Design

Conceptual Design

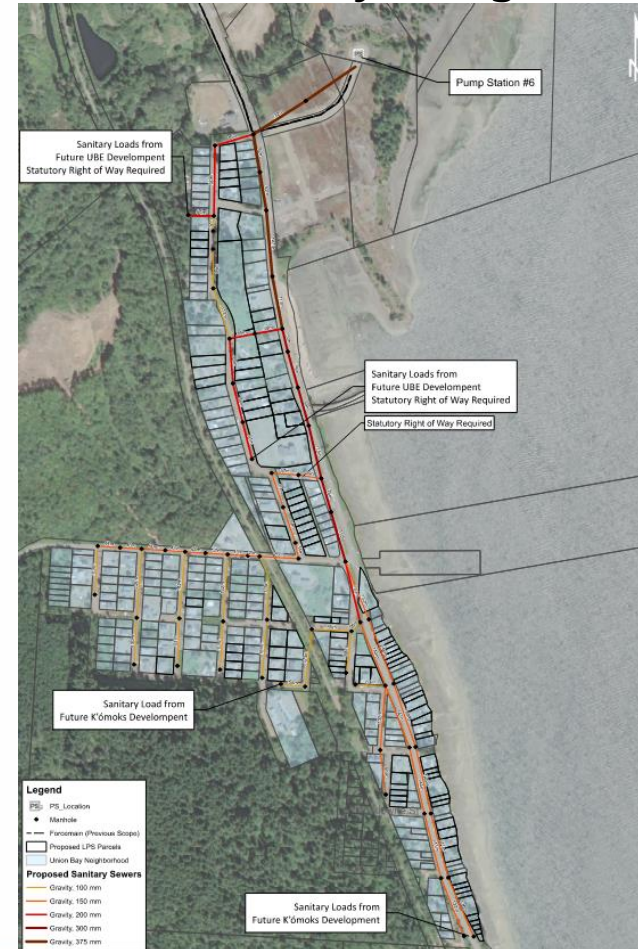
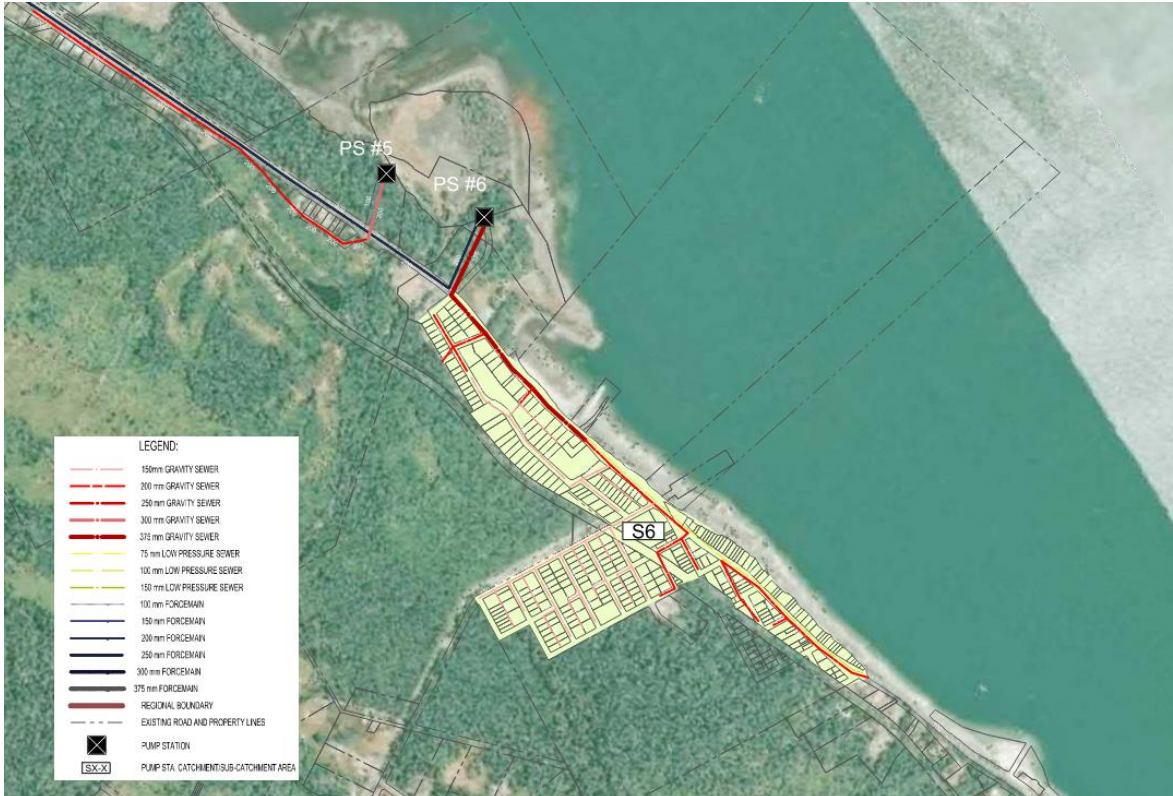

Planview: Kilmarnock

Preliminary Design

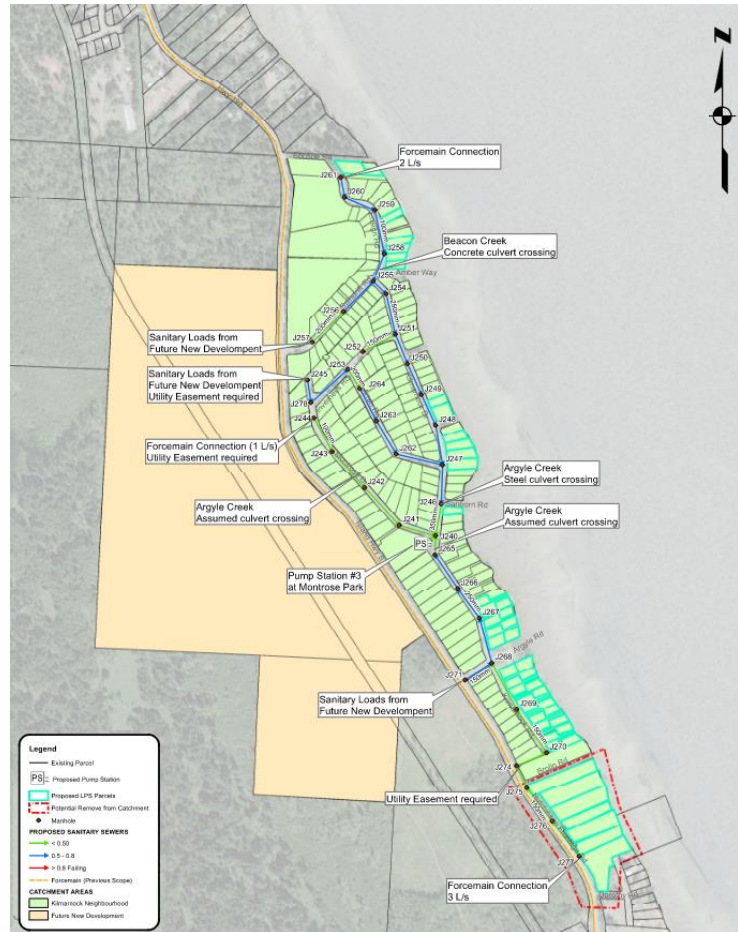

Background

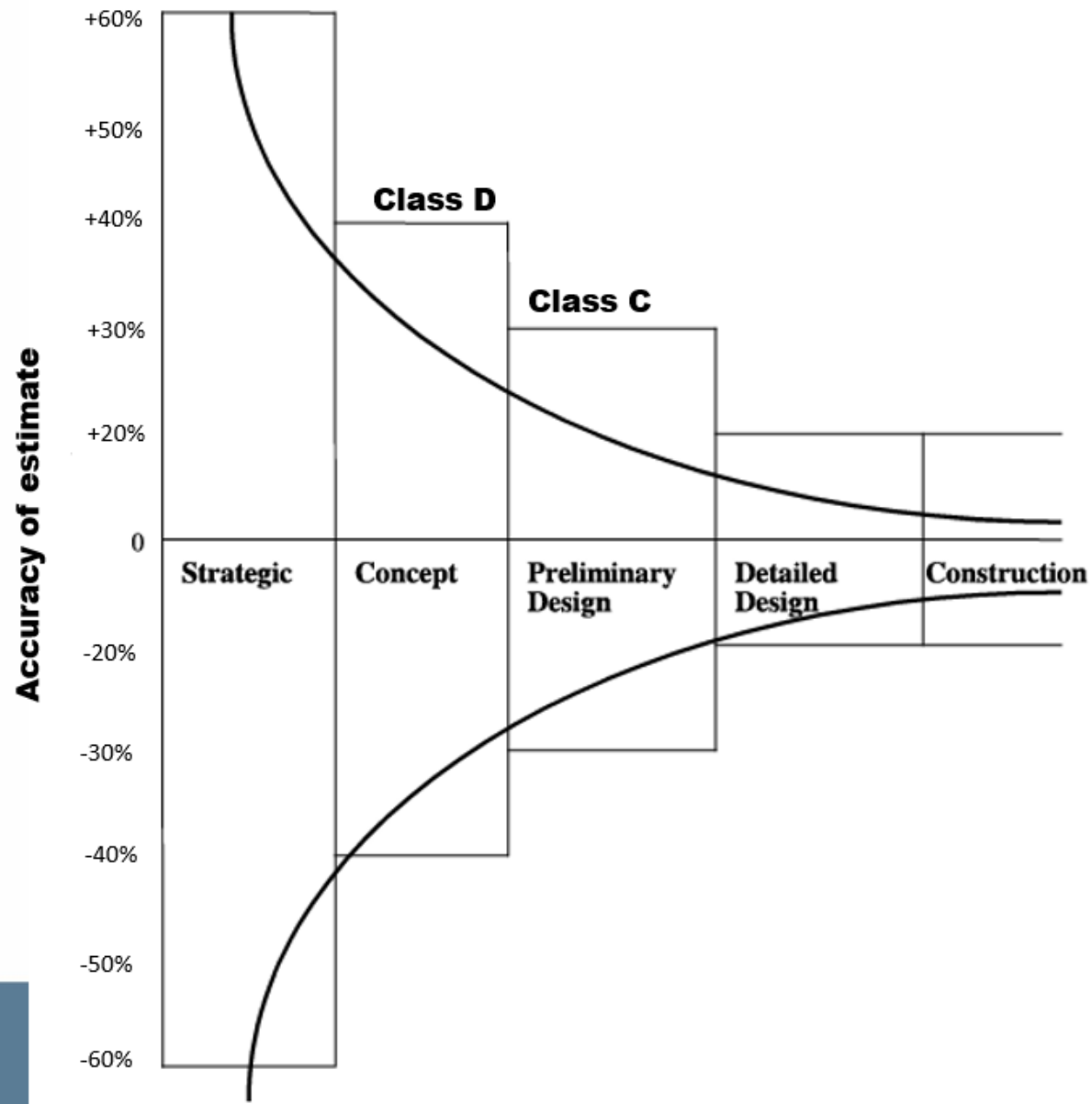

Reasons for Cost Changes

- Preliminary Design
 - Additional information such as LIDAR and base mapping
 - Hydraulic modeling
 - Diameter of Pipe
 - Depth of pipe
 - Isolation and air valves
 - Service connection increased in length
 - Inflation
 - Design Update
 - Highway and railway crossing
 - Public input
 - Import Fill material

Capital Cost Estimate

		Costs Presented in Previous TACPAC	October 2023 Cost Estimate
Forcemain	North Royston & South Royston	\$31,569,000	\$27,128,000
Collection System	Royston (S1-3 only)	\$4,852,000	\$7,177,000
	Royston (Remainder)	\$6,247,000	\$10,569,000
	Kilmarnock	\$8,243,000	\$7,553,000
	Union Bay	\$10,615,000	\$14,088,000

Kilmarnock and Union Bay Pump Station cost estimates have increased by an average 5% from cost presented in previous TACPAC.

Committee Considerations



Resident Cost Update

- One-time costs
- Updated project costs
- Shared infrastructure
- Partner contributions
- Allocation of full \$30m CCI grant
- Additional \$1.25m CWF for Area A

	COST PER HOUSEHOLD	
One Time Costs	LWMP Addendum	June 2023
Connection from home to new pipe at property line	\$ 1,500 – \$ 9,500* *includes LPS equipment where needed	\$ 1,500 – \$ 6,500
Decommissioning of septic system	\$ 1,000 – \$ 2,000	\$ 1,000 – \$ 2,000
Total	\$ 2,500 – \$ 11,500	\$ 2,500 – \$ 8,500
Annual Costs	LWMP Addendum	June 2023
Borrowing (25 years)	\$ 1,200 - \$ 1,500	\$ 1,400 - \$ 1,700
Operations + Maintenance (ongoing)	\$ 530 – \$ 650	\$ 530 – \$ 650
Total	\$ 1,730 – \$ 2,150	\$ 1,930 – \$ 2,350

South Services Projected Tax Escalation

Purpose

- Planned essential services
- Affordability
- Portion of Area A
 - Royston and Union Bay
 - Specific increase associated with 152 Royston and 311 Union Bay households

Service Pressures

- Sewer Extension South
- Water South Extension
- Recreation Facilities
- Enhanced Garbage Collection
- Utility Water Rate Review

South Services Projected Tax Escalation

Basis of Analysis and Assumptions

- Based on current info and the 2023-2027 Financial Plan
- Sewer Extension South - Class D estimate and public information provided during open houses
- Water South Extension– April 17, 2023 update report
- One-time costs to connect to sewer are not included
- Royston Garbage Collection Service – September report
- Fire Service Union Bay – planned with current financial plan
- Utility Water Rate Review – as provided in October 16, 2023 report
- Addresses services under the responsibility of CVRD
- Calculated on basis of single family residential property

South Services Projected Tax Escalation

2023 Total Charges	Royston		Union Bay	
	Tax	User Rate	Tax	User Rate
Common Services (tax)	\$833		\$833	
Unique Services (tax)	257		825	
Royston Fire (Courtenay Levy)	170			
Water Service	200		510	
Utility Rate Fees (existing service)		710		964
2023 Total Charges	\$2,170		\$3,132	
2027 Total Charges	Royston		Union Bay	
	Tax	User Rate	Tax	User Rate
Common Services (tax)	\$900		\$900	
Unique Services (tax)	280		1030	
Royston Fire (Courtenay Levy)	170			
Water Service	350		710	
Water Extension South	340*			
Recreation Facilities	60		60	
Utility Rate Fees (existing service)		935		1,066
Enhanced Garbage Collection Service		100		100
2027 Total Charges	\$3,135		\$3,866	

South Services Projected Tax Escalation

Area A Specific Households

Specific to Phase I Sewer Extension South– Future (2027) charges	Royston 152 Households		Union Bay 311 Households	
	Tax	User Rate	Tax	User Rate
Sewer Extension South (2025 estimated start) (household connection cost, financed with debt and spread across 25 years)	1,700		1,700	
Sewer Extension South (2026 estimated start) (maintenance and operations)		690		690
Total Projected Cost Sewer Extension South	\$2,390		\$2,390	
Overall Impact for Households connecting to Sewer Service – Total Future (2027) charges	\$5,525		\$6,256	

*Updated project financing tax estimate is \$1,200 - \$1,500, reducing total costs above by \$200

Discussion Paper #1 – Collection System design considerations

Description	Conceptual Design	Preliminary Design
Private property crossings (SRW's)	43 (Royston) + 64 (Union Bay)	4 (Royston) + 4 (Union Bay)
Approximate number of LPS connections	20 (Royston) + 44 (Union Bay)	88 (Royston) + 111 (Union Bay)

- Phase 1A & 1B
- No change in Kilmarnock – 4 SRWs & 46 LPS connections

Discussion Paper #2 – Phasing & boundary change requests

- Royston area
 1. Hyland Road
 2. Royston Road
 3. Hayward Ave
 4. Marine Drive
 5. Highway 19a
- Consideration of cost impacts

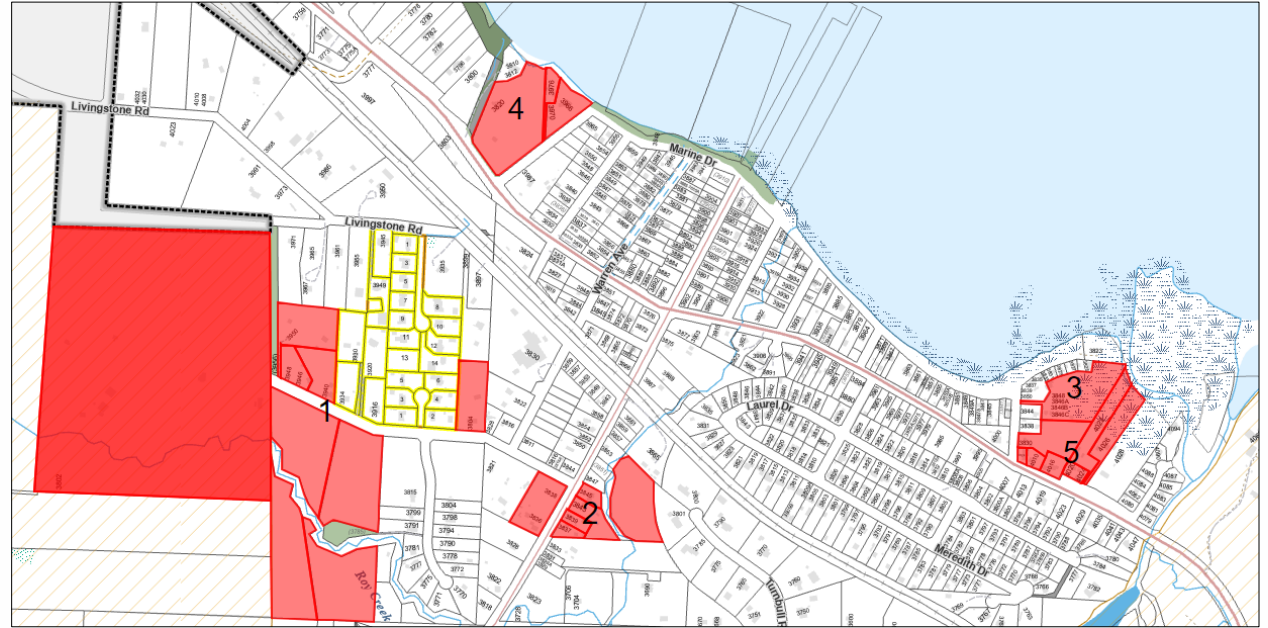

	Cost estimate (2023\$)	Additional properties serviced
1 - Hyland Road extension	\$613,000	7 (+ up to 27 if existing strata subdivisions connected)
2 - Royston Road extension	\$217,000	5
5 - Highway 19a	\$175,000	7 (shift from Phase 1B to 1A)

Draft Addendum Report

- Project design changes
 - Collection system
 - Royston pump station
 - Forcemain alternate alignment
- Cost changes/property owner impacts
- PACTAC Feedback for December Steering Committee meetings

CVRD Updates



Septic Deferral program

- May 2023 – LWMP Addendum Steering Committee
 - Support for septic deferral program to defer sewer operating costs for up to 5 years
- Proposed eligibility:
 - Septic system age <5 years at date of required sewer connection (~2028 for Phase 1A)
 - Type 2 or 3 systems
- Proposed eligible deferral costs:
 - Sewer operating costs (\$530 - \$650/year)
 - Private property costs – connection & septic decommissioning (\$2,500 - \$11,500)
- Deferral time – 5 years (or until property is sold)

Septic Maintenance Program

- October 16, 2023 EASC report
 - Support for region-wide program
 - Mandatory inspections in 'high-risk' areas
 - Mandatory pump-outs in all other areas
 - Requires BC cabinet approval of order in council
 - OIC request – Summer 2024
 - Inclusion in SES LWMP Addendum
 - Allows program to proceed in plan area if region-wide program doesn't move forward

Next Steps

- December 4
 - LWMP Addendum Steering Committee
- December 5
 - CVSS LWMP Steering Committee
- January 2024
 - Public open houses
 - Webinar
- March/April
 - PACTAC Meeting #5

Discussion / Questions

